

UHAND MANURE COLLECTOR



INNOVATIVE RIGID MECHANICAL SYNCHRONOUS 4WD SYSTEM

ADVANTAGES OF THE FULLY MECHANICAL STRUCTURE

The system uses a transfer case + dual drive shafts fully mechanical design, distributing engine power rigidly at a 1:1 ratio to the front and rear axles. This ensures identical torque output, enhancing traction and off-road capability from the source.

OFF-ROAD RECOVERY CAPABILITY

On low-traction surfaces such as wet ground or areas with manure residue, the 4WD system significantly improves vehicle traction and stability, preventing one-sided wheel slip and enabling reliable operation in challenging terrain.

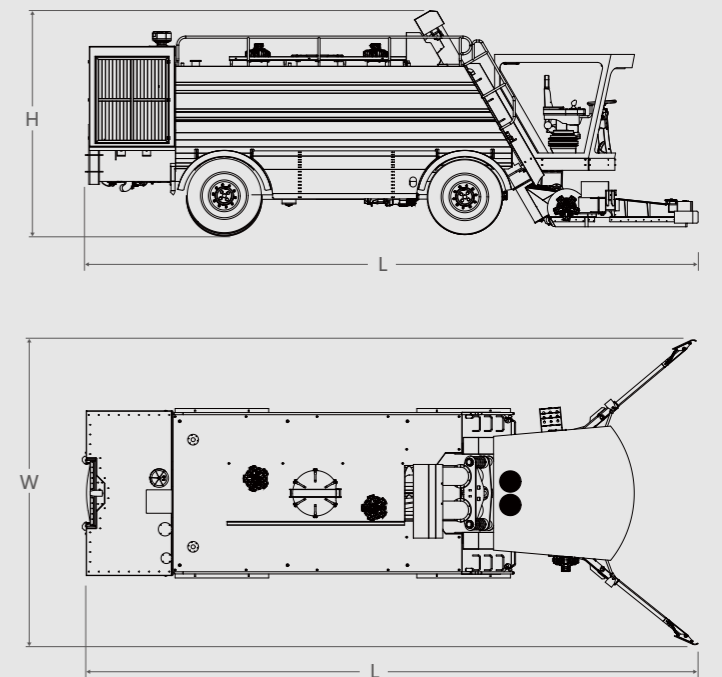

MANURE COLLECTOR 5–6 M³

| Model | | MC-5 | MC-6 |
|----------------------------|---------------------|----------------------------|----------------------------|
| Working Dimensions (L×W×H) | mm | 5500×4100×2400 | 5700×4100×2400 |
| Travel Dimensions (L×W×H) | mm | 4500×2050×2700 | 4700×2350×2700 |
| Curb Weight | kg | 4200 | 4500 |
| Actual Payload | kg | 5000 | 6000 |
| Effective Tank Volume | m ³ | 5 | 6 |
| Collection Width | m | 1.9 | 1.9 |
| Auger Ground Clearance | mm | 300 | 300 |
| Engine Power | kW | 91.3 | 91.3 |
| Emission Standard | | National IV | National IV |
| Fuel Tank Capacity | L | 120 | 120 |
| Unloading Method | | Hydraulic Cylinder Lifting | Hydraulic Cylinder Lifting |
| Discharge Rate | m ³ /min | 5 | 6 |

MANURE COLLECTOR 15 M³

| Model | | MC-15 |
|----------------------------|-------------------|-------------------------|
| Effective Tank Volume | m ³ | 15 |
| Working Dimensions (L×W×H) | mm | 8390×2530×3250 |
| Travel Dimensions (L×W×H) | mm | 8390×2530×3700 |
| Total Weight | t | 16.5 |
| Engine Power | kW | 206 |
| Engine Brand | | Yuchai |
| Emission Standard | | National IV |
| Drive Mode | | 4WD |
| Cleaning Efficiency | m ³ /h | ≥50 |
| Collection Method | | V-Type Foldable Scraper |
| Unloading Method | | Auger Discharge |
| Travel Speed | km/h | 20 |

MANURE COLLECTOR 8-12 M³

| Model | | MC-8 | MC-10 | MC-12 |
|----------------------------|----------------|-------------------|-------------------|----------------|
| Effective Tank Volume | m ³ | 8 | 10 | 12 |
| Working Dimensions (L×W×H) | mm | 6500×2600×2900 | 6800×2600×3000 | 6800×2600×3200 |
| Travel Dimensions (L×W×H) | mm | 6350×2600×3260 | 6650×2600×3360 | 6650×2600×3560 |
| Working Speed | km/h | 1.5-20 | 1.5-20 | 1.5-20 |
| Collection Width | mm | 1750-4200 | 1750-4200 | 1750-4200 |
| Collection Speed | km/h | 1.5-8 | 1.5-8 | 1.5-8 |
| Engine Power | kW | 110.3 | 110.3 | 110.3 |
| Emission Standard | | National IV | National IV | National IV |
| Tank Thickness (Base/Side) | mm | 6/3 | 6/3 | 6/3 |
| Tire Specification | | 315-60-R22.5 | 315-60-R22.5 | 315-60-R22.5 |
| Wheel Configuration | | Front 2/Rear 2 | Front 2/Rear 2 | Front 2/Rear 2 |
| Unloading Method | | Hydraulic Lifting | Hydraulic Lifting | Hydraulic Lift |



*Product images & specs are for illustrative purposes only. Minor variations (due to production batches or upgrades) may occur, with no impact on core functions. Actual product shall prevail. For inquiries, contact our sales team.

UHAND MANURE COLLECTOR



MULTI-MODE STEERING SYSTEM – FLEXIBLE ADAPTATION

Coordinated Steering & Locking Modes

The system features “Coordinated Steering” and “Rear-Axle Lock” modes. In Coordinated mode, the front and rear axles steer synchronously, enabling diagonal translation and allowing operation in narrow alleys. In Lock mode, the front-wheel steering is restored for optimal performance in open spaces.

One-Touch Mode Switching

Operators can easily switch between hydraulic lock and electronic control valves via the LCD display, allowing flexible adaptation to different workspaces. This significantly enhances maneuverability and operational convenience.

MANURE COLLECTOR – STRUCTURAL OVERVIEW



Collection Head



Cab Control System



Hydraulic Motor & Gearbox System



Transfer Case & Hydraulic Pump Assembly



Front Headlights

HIGH-EFFICIENCY FEEDING TECHNOLOGY

The combination of an elevated collection head and large-capacity, high-speed scraper and deflector wheels forms an integrated collection system between the hopper and chassis. This design significantly increases material throughput per cycle, quickly directing more material into the auger compartment. The auger compartment is equipped with dual augers, further accelerating material transfer to the hopper, doubling overall manure collection speed.

ADAPTIVE TERRAIN ADJUSTMENT TECHNOLOGY

The collection head features a longitudinally adjustable pressing mechanism, automatically regulating its tilt. This ensures the collection head remains in close contact with the ground, while also adapting to changes in vehicle height caused by increasing material weight in the hopper. This prevents missed material and enhances performance across varied terrain.

GROUND PROTECTION & CUSHIONING TECHNOLOGY

The collection head’s sliding track is fitted with high-strength springs to cushion its weight. Adjustable spring tension nuts allow fine-tuning of the spring force, greatly reducing pressure on the ground. This design prevents scratches or surface damage, protecting the ground during operation.